

Entrée USB-C (pour recharge accu)

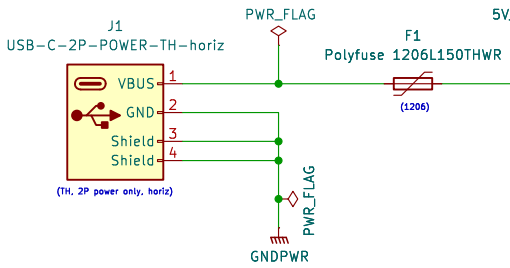

Chargeur accu li-ion (TP4056)

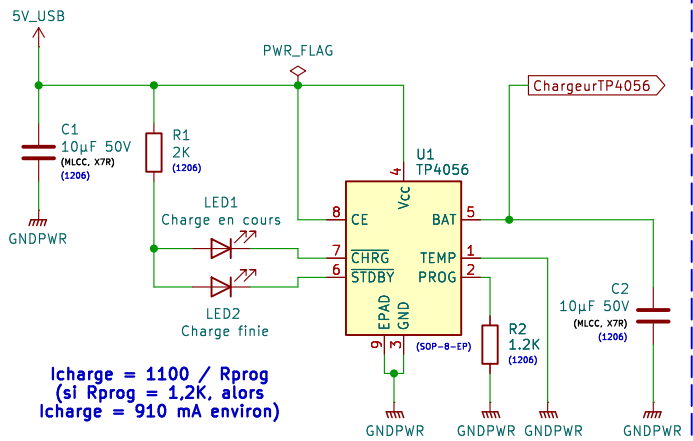

Accu li-ion 18650 + protections

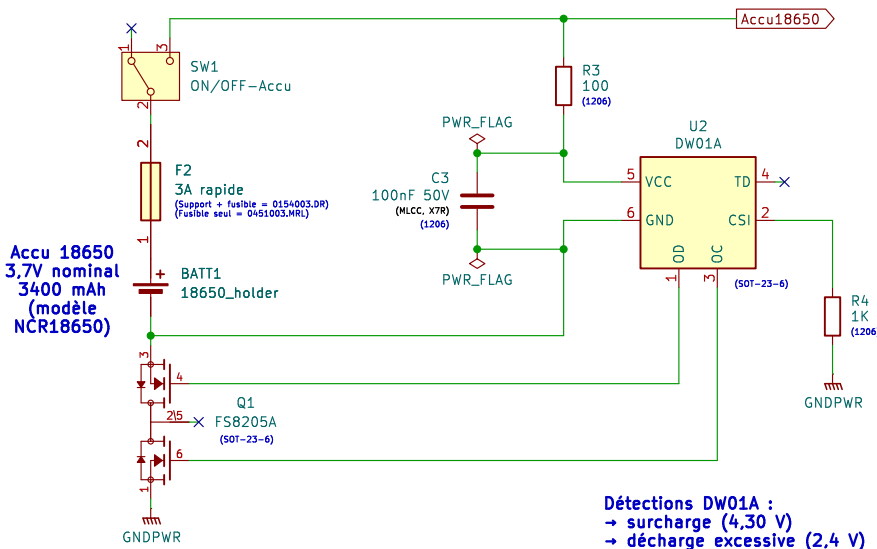

Sortie USB-A (1A max)

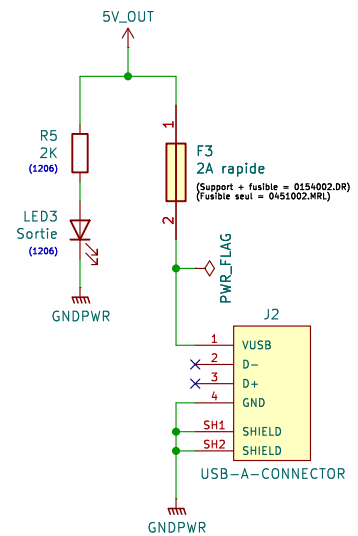

Boost (accu li-ion → 5V)

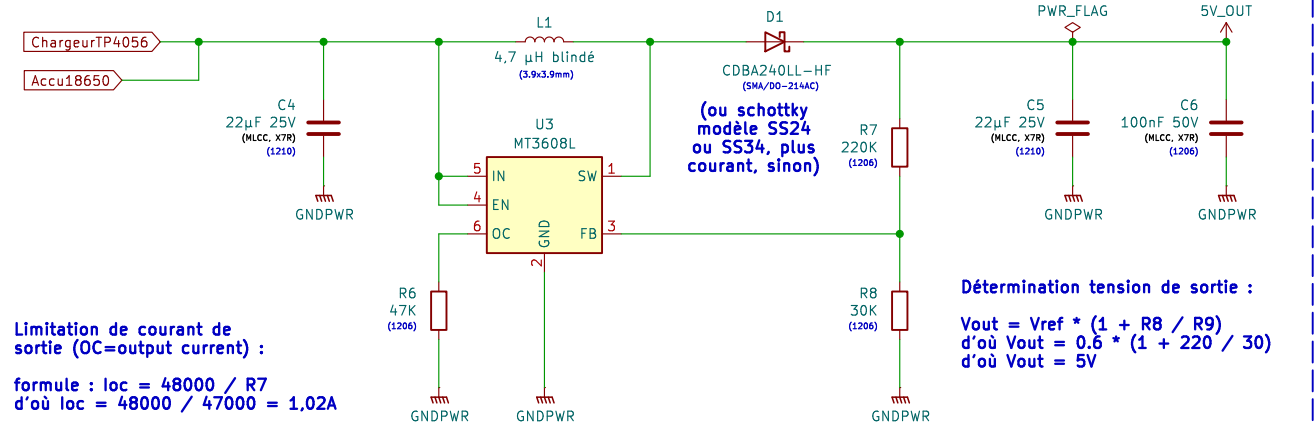

Trous de montage

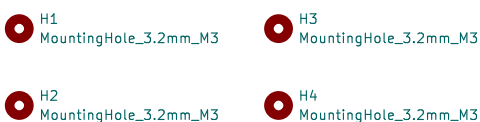

BY-NC-ND 4.0 CC (<https://creativecommons.org/licenses/by-nc-nd/4.0/deed.fr>)
Jérôme TOMSKI (<https://passionelectronique.fr/>)

Sheet: /

File: Alim_USB_5V-1A_rechargeable_18650.kicad_sch

Title: Batterie nomade (alim USB 5V/1A rechargeable 18650)

Size: A4

Date: 2025-05-24

Rev: V1

KiCad E.D.A. 9.0.4

Id: 1/1